

Getting Started with Induction Cap Sealing



THANK YOU FOR DOWNLOADING

Getting Started with Induction Cap Sealing

Induction cap sealing is a wonderful technology used by packagers around the world to **prevent leaks, preserve freshness, & provide tamper evidence.**

Enercon equipment has **sealed billions & billions of containers** & our team is passionate about helping our customers **Achieve a Perfect Seal.**

This eBook shares our team's **application experience, equipment design expertise,** & the lessons learned from **partnering with leading packagers** over several decades.

We believe you'll find everything you need to get started with induction sealing. And if you don't, **please contact us** we want to learn from you.

Thank you for your trust.



DAIRY

BEVERAGE

FOOD

CHEMICAL

PHARMACEUTICAL

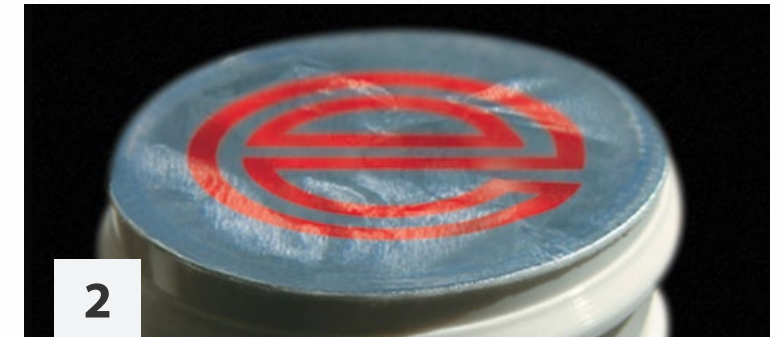

Table of Contents



1

Why use induction sealing?



2

What you need for induction sealing.

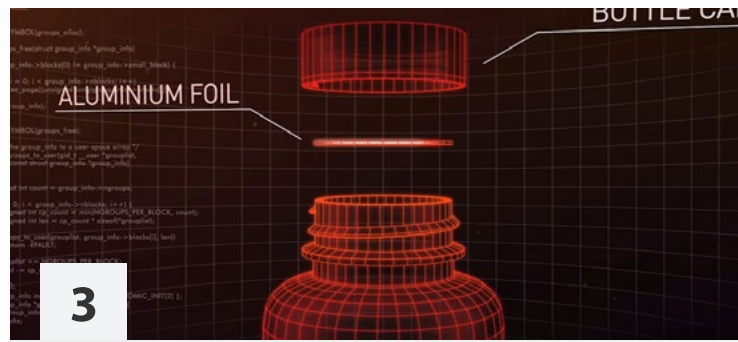

3

How induction sealing works.



4

Selecting the right cap sealer.



5

Expert tips for Achieving a Perfect Seal.



WHY USE INDUCTION SEALING



Protect your Products Provide Tamper Evidence

Tamper evident liners leave evidence that the container has been opened.

The FDA recognizes induction sealing as a form of tamper evidence.

“We wanted tamper evidence to increase consumer confidence and because there’s occasionally rough handling in the mail. With an induction seal, even if the cap should be broken for some reason, the bottle remains sealed. You have to destroy the bottle or the liner to get into the contents.”

Dave Booher *Pharmacy Manager*
BOOHER PRESCRIPTION SOLUTIONS

Residue on the container lip provides tamper evidence.



Prevent Leaks

Induction seals prevent leaks and can stand up to some pretty heavy pressure.

This ensures your products will not leak during shipping, while in inventory, or before your consumer is ready to use your product.

Amazon, UPS, FedEx, major retailers and shipping operations require a form of leak protection such as an induction seal.

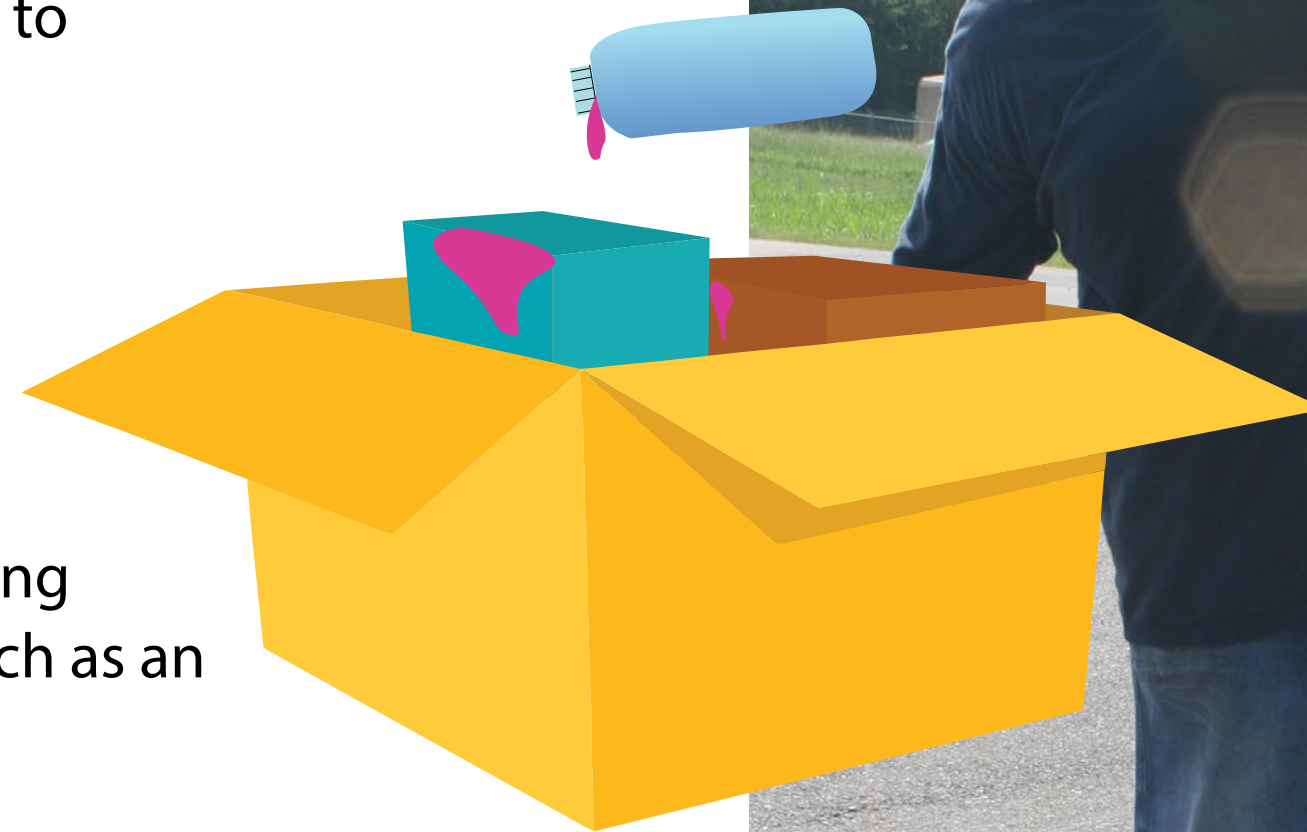

“Customer complaints are nearly eliminated, 99% of our problems were solved with the induction sealer. It was a godsend.”

Darryl King *Director of Operations*
FLORATINE PRODUCTS GROUP, INC.

Packaging Requirements for e-Commerce Packaging



- Position bottles that contain liquids upright
- Use an inner seal and perforated breakaway cap
- The packaging must be able to contain leaks



**Double Seal Required
Tightened lid that cannot be easily opened and one of the following:**

- A "safety seal" (induction seal)
- A manufactured seal around the outside of the neck of the product (shrink band)



- Make certain that caps or covers are applied securely...do not loosen during transit ... leak
- ...add a heat induction foil seal to help prevent leakage
- When shipping liquids in a sealed bottle,apply closures with the correct application torque
- ...application torque will also help prevent closures from backing off..

"All products shipped for the television shopping network or any other customers that use UPS or FedEx are induction sealed for leak prevention..."

Tommy Lancaster Chief Operating Officer
BRYSON INDUSTRIES

Induction Sealing is Used in Many Industries & Applications

BEVERAGE, FOOD & DAIRY



[LEARN MORE >](#)

Preserve freshness, prevent leaks and deter tampering for products.

CHEMICALS, LUBRICANTS & PETROLEUM



[LEARN MORE >](#)

Prevent containers from leaking.

COSMETICS & PERSONAL CARE



[LEARN MORE >](#)

Ensure consumer confidence & preserve product integrity.

PHARMACEUTICAL



[LEARN MORE >](#)

Provide tamper evidence and meet FDA compliance.

NUTRACEUTICAL



[LEARN MORE >](#)

Block oxygen and moisture from contaminating products.

LIQUIDS & POWDERS



[LEARN MORE >](#)

Gain insights between sealing dry and liquid products.

CANNABIS



[LEARN MORE >](#)

Protect product freshness and integrity, provide tamper evident packaging.

CLOSURE TYPES



[LEARN MORE >](#)

Cap style is an important consideration when sealing your products.

WHAT YOU NEED FOR INDUCTION SEALING



What Materials you need for Induction Sealing

- ✓ High-quality cap with a compatible induction liner inside.
- ✓ Container- usually threaded.
- ✓ Make sure you purchase high quality containers, liners & caps. Inconsistency will undermine your sealing success.



Information to Share with your Cap & Container Suppliers

Ensure you are using the right materials

Purpose of sealing

- Prevent Leaks
- Preserve Freshness
- Tamper Evidence

Liner Removal Characteristics

- Clean Peel or Tamper Evident

Type of Product to be Sealed

- Liquid, Oily or Dry
- Acidic/Caustic

**GET A LIST OF
CAP & INDUCTION
LINER SUPPLIERS**



What Equipment you need for Induction Sealing

An Induction Sealer



Production Model

- For use with a conveyor



Hand Held

- For manual operations

Information to share with your Induction Cap Sealer Supplier

- Line Speed
- Type of product to be sealed
 - Liquid
 - Dry
 - Oily
 - Powder
 - Flammable
- Is the product sealed after hot, ambient or cold fill
- Liner Size & Type
- Cap Size & Type
 - Child Resistant
 - Continuous Thread
 - Dispensing

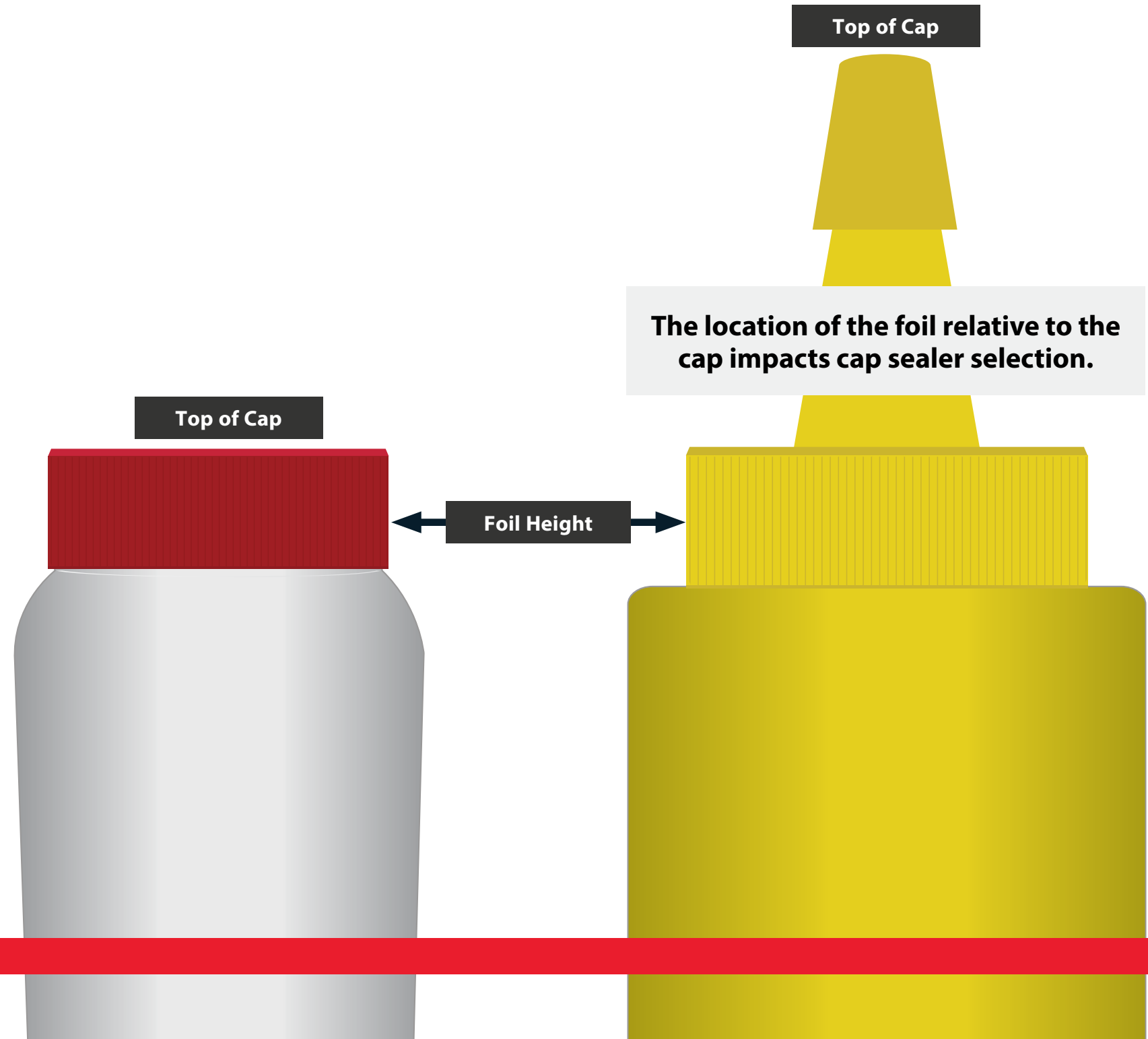

HOW INDUCTION SEALING WORKS

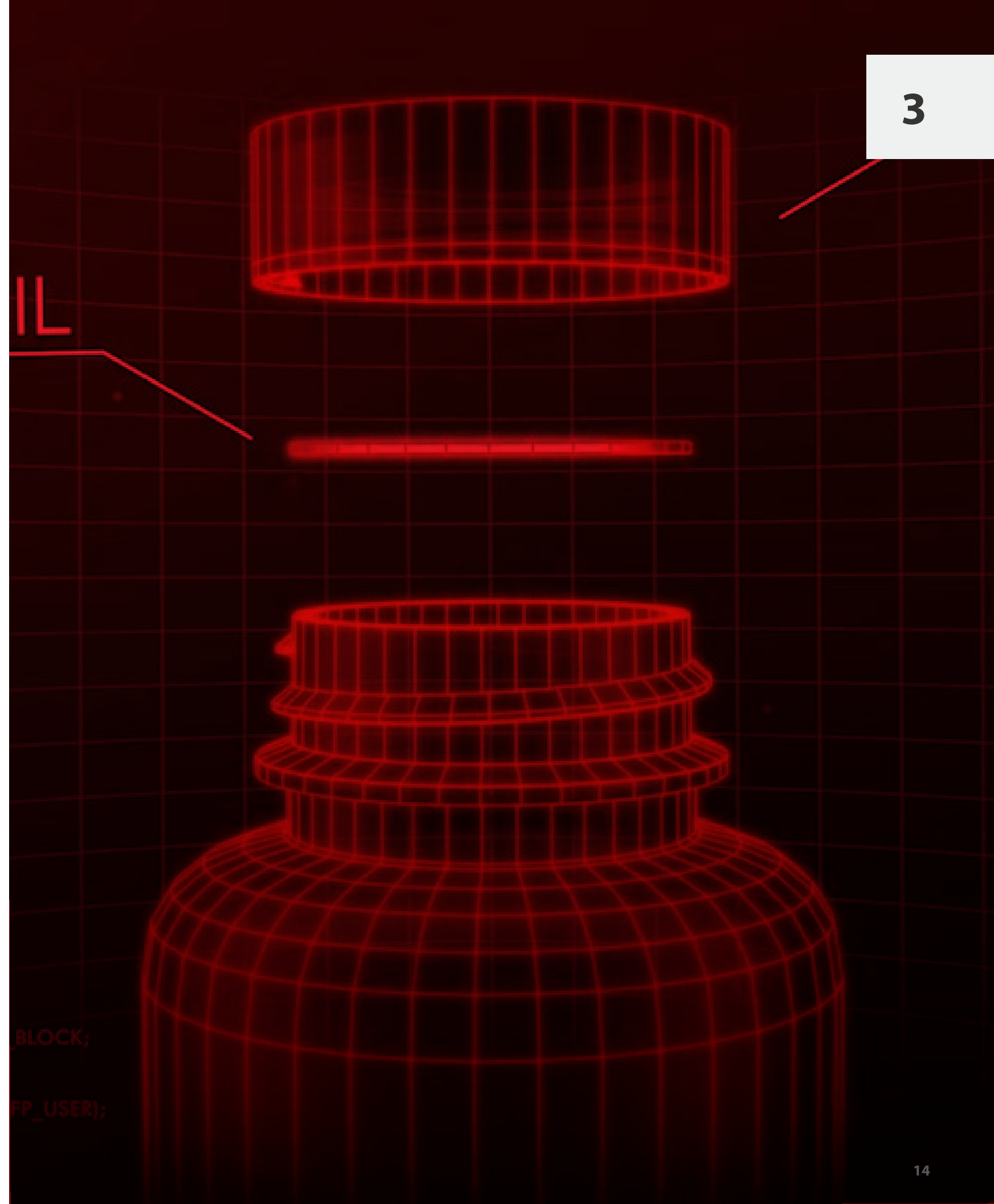

BLOCK;

FP_USER);

The Cap Applies Pressure on the Liner

The pressure that keeps the liner in contact with the lip of the container is provided by downward application torque of a properly applied cap.

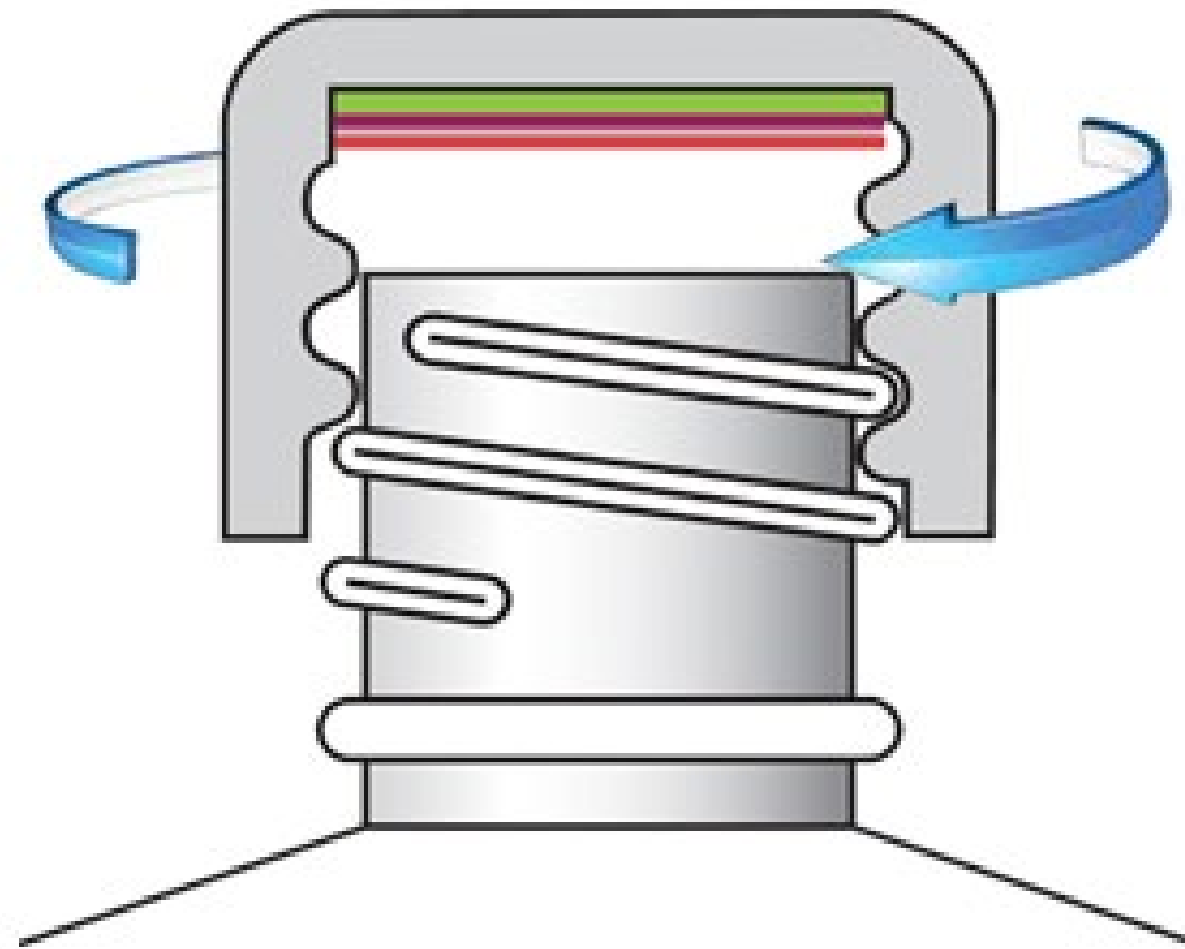

PROPER PRESSURE IS KEY TO SUCCESSFUL INDUCTION SEALING

Cap Application Torque General Guidelines

CAP SIZE (MM)	TORQUE (INCH/LBS)
15	6 to 9
18	7 to 9
20	8 to 12
22	9 to 14
24	10 to 16
28	12 to 18
33	15 to 25
38	17 to 26
43	18 to 27
48	19 to 30
53	21 to 36
58	23 to 40
63	25 to 43
70	28 to 50
83	40 to 60
89	45 to 65
100	50 to 70
110	52 to 73
120	55 to 75

An Induction Sealer has two Main Components

Power Supply

- Converts supplied electrical energy to a high frequency, regulated AC current.

Sealing Head

- The sealing head transforms the electrical energy into a magnetic field to which the foil liner is exposed.



Heat and Time

Capped containers are conveyed under the electromagnetic field

The cap sealer's electromagnetic field heats the foil liner and melts the polymer which bonds with the container lip to create a hermetic seal.

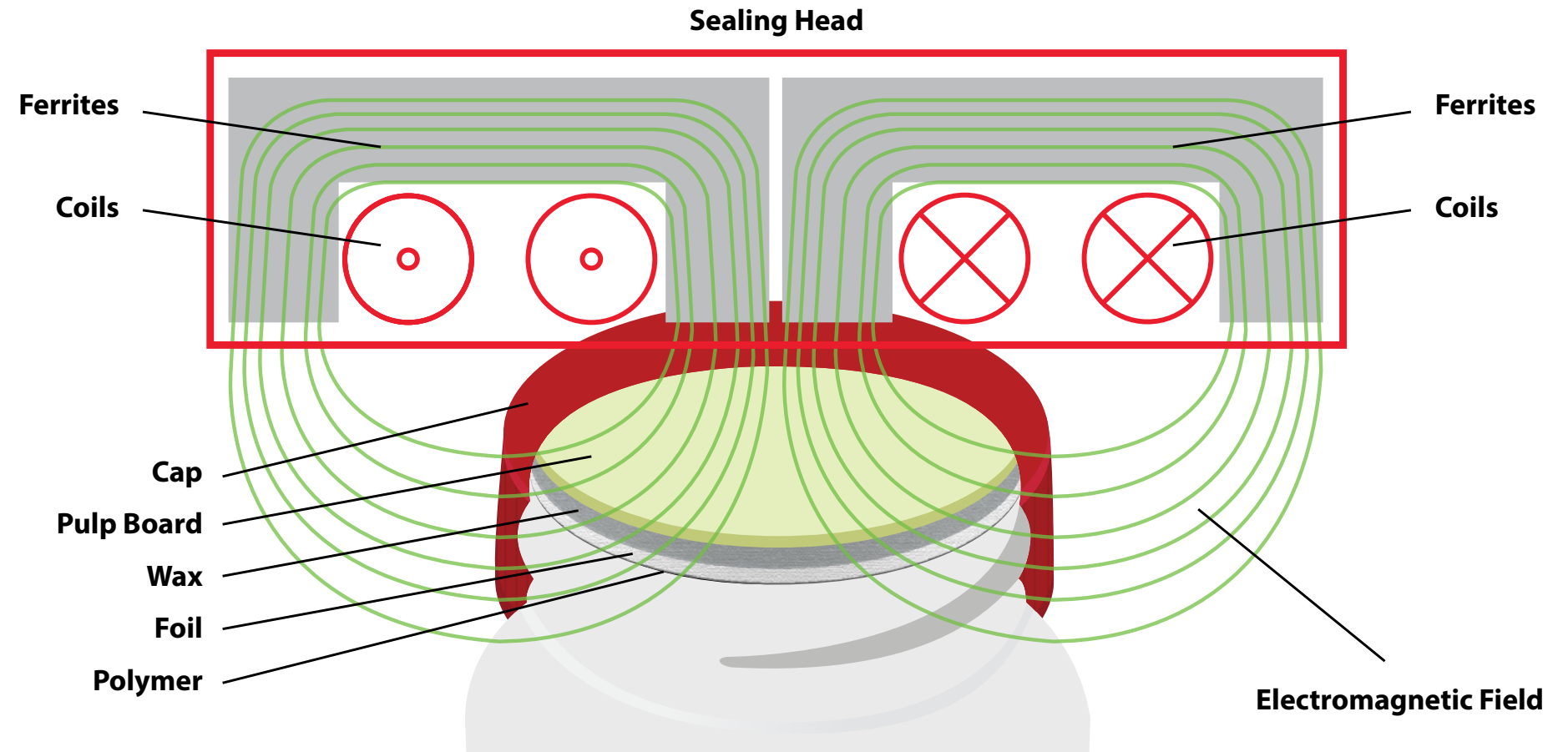
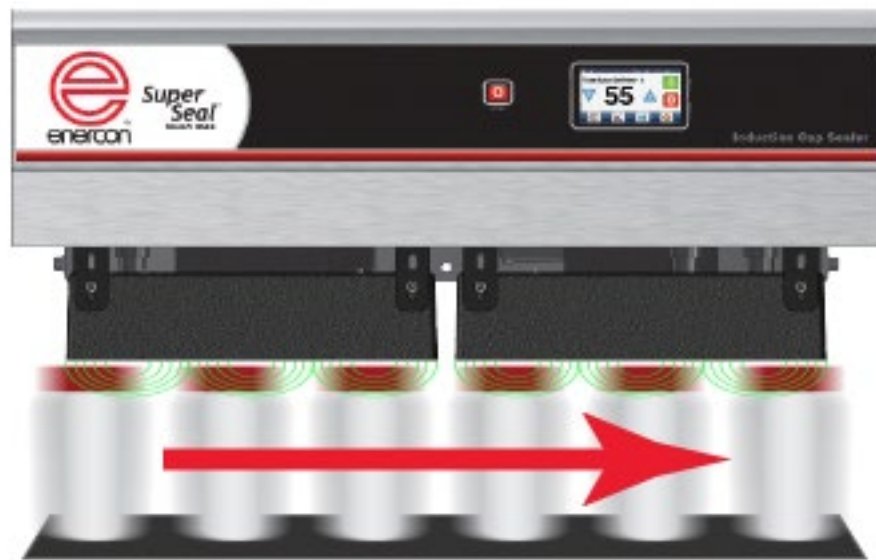
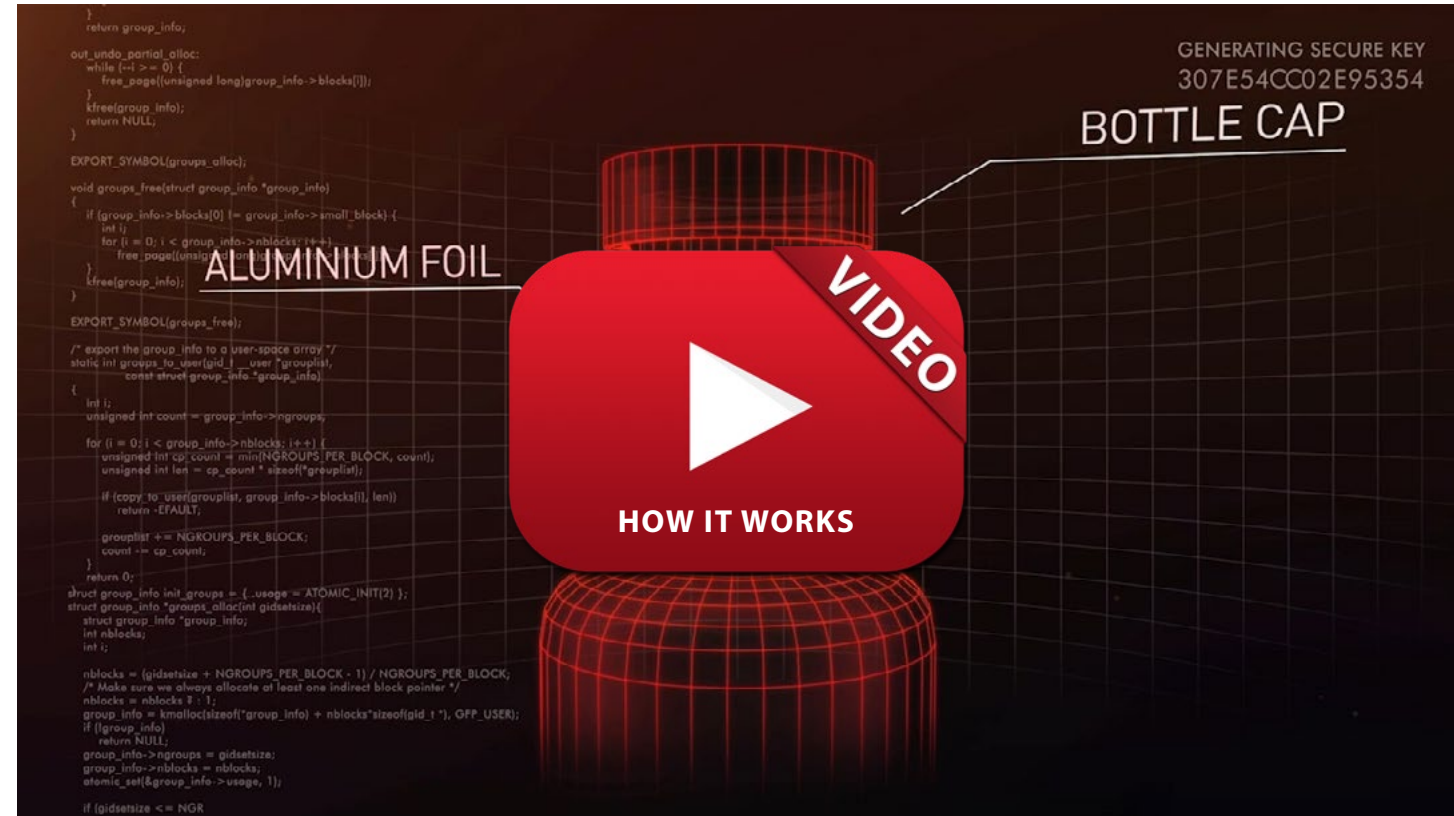

SELECTING THE RIGHT CAP SEALER



Enercon Experts will help you find the right cap sealer for your application



Enercon's Experts have helped packagers seal billions and billions of containers around the world.

And we can help you determine the right power supply and sealing head to seal your products.

Factors affecting induction sealer choice:

Sealing Power Needed

- Size of foil
- Type of cap
- Line Speed

Sealer Configuration

- Power Supply Size
- Sealing head design
- Desired options

**GET ADVICE FROM
AN EXPERT**

CLICK OR CALL +1 (262) 255-6070

Free Cap Seal Laboratory Testing

Enercon offers the packaging industry free expert evaluations of cap, liner and container compatibility, ultimately recommending the best induction sealing solution.

Our lab is stocked with our complete line of induction cap sealers from manual production systems to those for high speed packaging lines.

R&D, Troubleshooting and Training

We help packagers with research & development projects, troubleshooting existing applications, and we can even help train your team how to achieve a perfect induction seal.



Induction Cap Sealer Models

Click on each cap sealer to learn more.



SUPER SEAL™ MAX

**High Speed
Induction Sealer**

Most powerful cap sealer with full feature set.

[GET MORE INFORMATION >](#)



SUPER SEAL™ TOUCH

**Advanced
Induction Sealing**

Sealing power with intuitive touchscreen interface.

MOST POPULAR

[GET MORE INFORMATION >](#)



SUPER SEAL™

**Induction Cap
Sealing Machine**

The flagship model offers reliable sealing and proven technology.

[GET MORE INFORMATION >](#)



SUPER SEAL™ JR

**Hand Held
Induction Sealer**

Designed for labs and manual packaging operations.

[GET MORE INFORMATION >](#)

Enercon Sealing Head Design

The cap sealer power supply energizes the sealing head which converts the energy into sealing power.

How much sealing energy is transferred to the foil is dependent on the size of the foil and geometry of the cap.

Enercon has engineered a wide variety of sealing heads, including an all-in-one universal sealing head, to optimize sealing performance for your specific application.

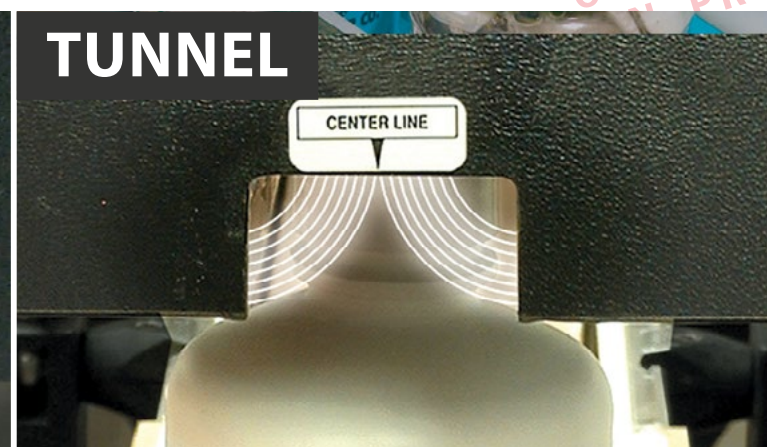
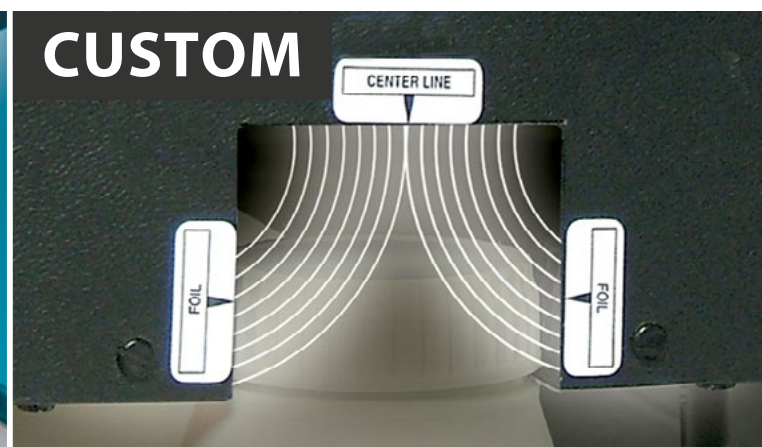

EXPERT TIPS FOR ACHIEVING A PERFECT SEAL



Not all Induction Liners are Created the Same

Changing your liner type or liner thickness may impact the sealing power required to Achieve a Perfect Seal.

ONE PIECE LINER

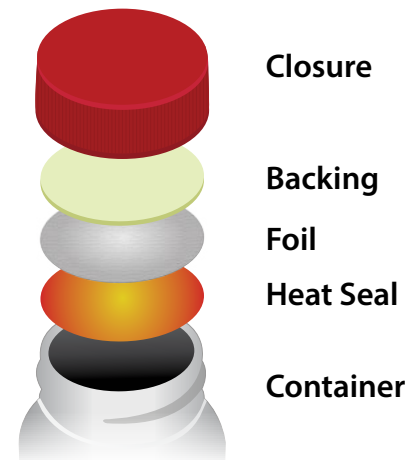

Induction seals prevent leaks and preserve product freshness. Packagers should specify whether the induction liner will peel away cleanly or leave indication of tamper evidence. Peelable liners can include tabs which make the liner easier to remove.

TWO PIECE LINER

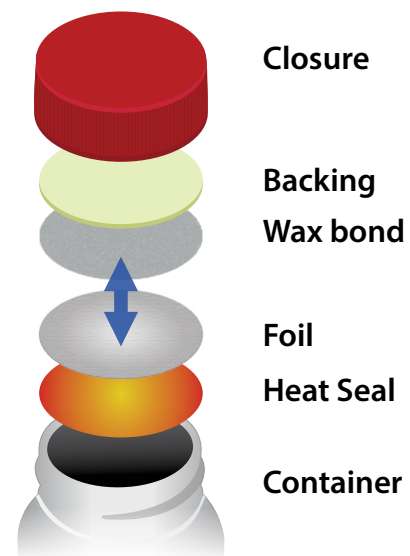

These liners are referred to as two piece liners. They rely on a wax or mechanical bond between the foil liner and a foam or pulpboard backing piece which remains in the cap when it is removed.

HIGHER BARRIER VERSION

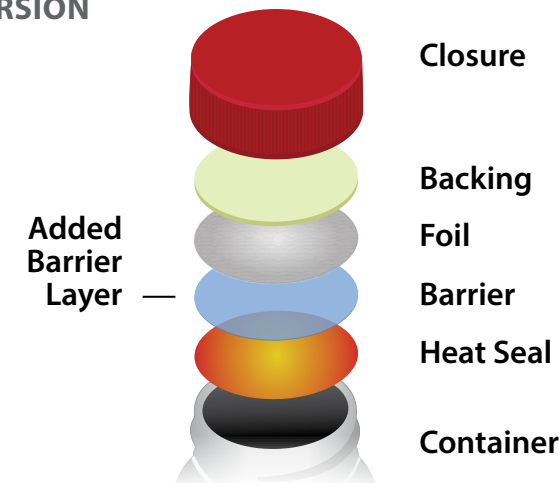

Certain products containing oils and chemicals may require an additional barrier layer to protect the foil liner.



PRESSURE SENSITIVE LINERS DO NOT CREATE A HERMETIC SEAL AND ARE NOT TAMPER EVIDENT.

“In an endeavor to get our liquid product to the end user without damages, heat induction seals were superior to pressure sensitive liners or seals. The heat induction gives our product a seal that nothing else can.”

Newton Hayes *Owner*
SOUTH CASCADE ORGANICS

Set up Tips

- Align products with the center of the conveyor
- Ensure sealing head is parallel to the conveyor
- Set the sealing head height to 1/8" above the cap
- For deep tunnel align height with liner height indicator

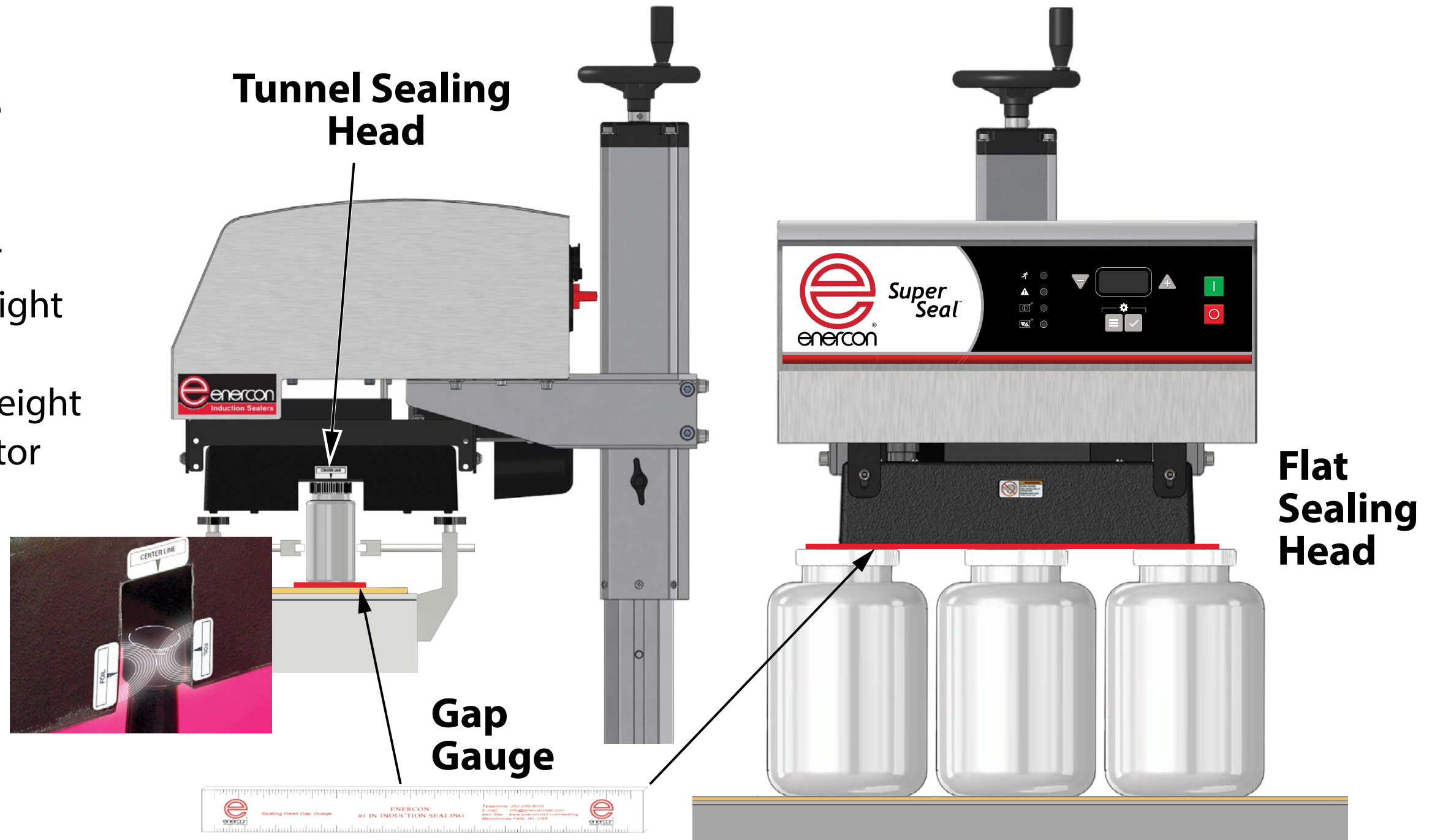

How much power do I need?

How to find your induction sealing operating window

The window is the range between the minimum & maximum power levels that achieve a good seal. After determining your operating window, select a power level within this range to run production based on the desired seal strength and peelability your product requires.

1 Find the Minimum Power Level that Produces a Good Seal

Try sealing your first container at 50% power. Follow the instructions below based on your results until you determine the minimum power level that achieves a good seal. Be sure your conveyor speed is set to your actual production rate.



2 Find the Maximum Power Level that Produces a Good Seal

Seal your first container at a power level that produces a good seal. Follow the instructions below based on your results until you determine the maximum power level that achieves a good seal.

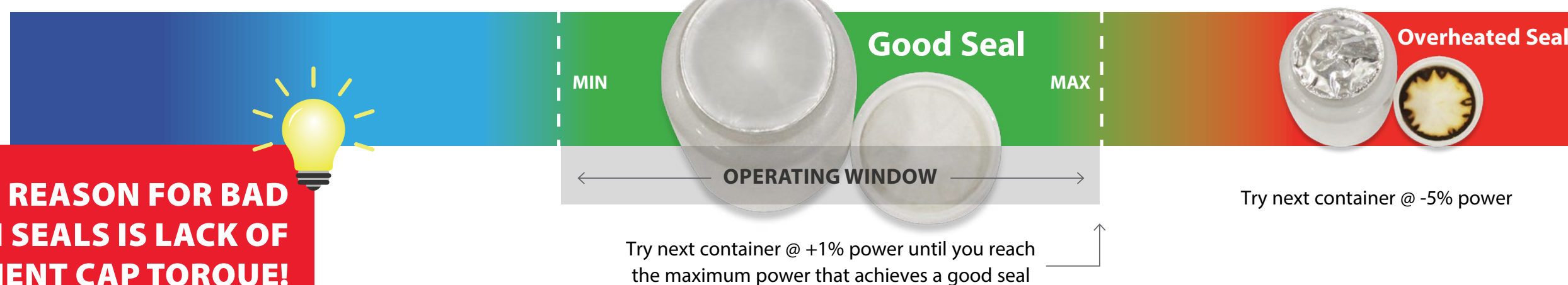

#1 REASON FOR BAD INDUCTION SEALS IS LACK OF SUFFICIENT CAP TORQUE!

Troubleshooting Induction Seals

SEAL CHARACTERISTICS AND REMEDIES

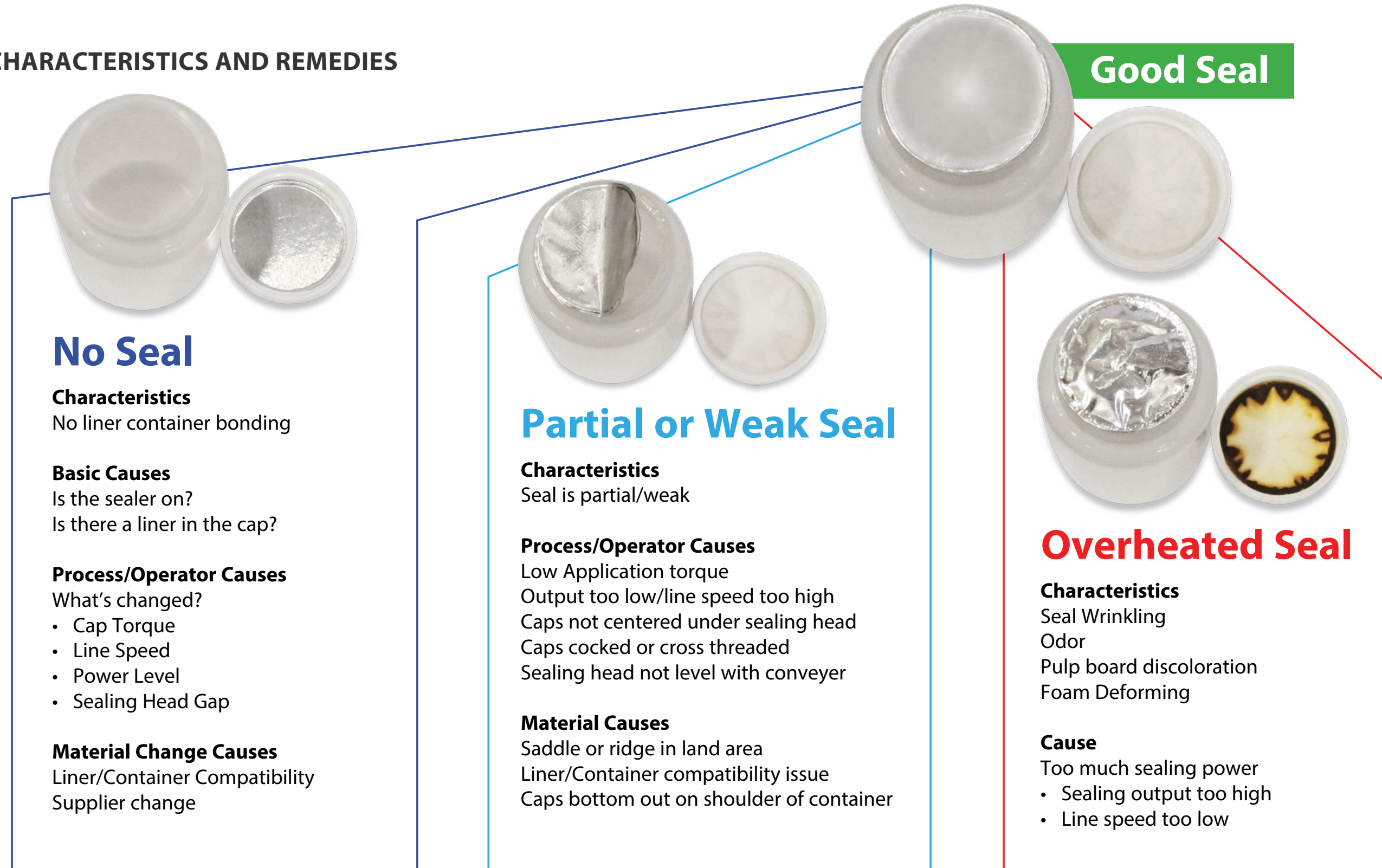

No Seal

Characteristics

No liner container bonding

Basic Causes

- Is the sealer on?
- Is there a liner in the cap?

Process/Operator Causes

What's changed?

- Cap Torque
- Line Speed
- Power Level
- Sealing Head Gap

Material Change Causes

- Liner/Container Compatibility
- Supplier change

Partial or Weak Seal

Characteristics

Seal is partial/weak

Process/Operator Causes

- Low Application torque
- Output too low/line speed too high
- Caps not centered under sealing head
- Caps cocked or cross threaded
- Sealing head not level with conveyer

Material Causes

- Saddle or ridge in land area
- Liner/Container compatibility issue
- Caps bottom out on shoulder of container

Good Seal

Overheated Seal

Characteristics

- Seal Wrinkling
- Odor
- Pulp board discoloration
- Foam Deforming

Cause

- Too much sealing power
- Sealing output too high
- Line speed too low

Global Perspective and Local Support from a World Leader

Since 1974 Enercon has brought innovative and cost-effective solutions to manufacturers.

Our team is committed to your success & will provide you the finest application expertise & product support.

We invite you to consult with us on your next project.

Enercon's global operations are supported by an international network of equipment and application experts who provide you with global perspective and local support.

**CONNECT WITH OUR
APPLICATION EXPERTS**

CLICK OR CALL +1 (262) 255-6070

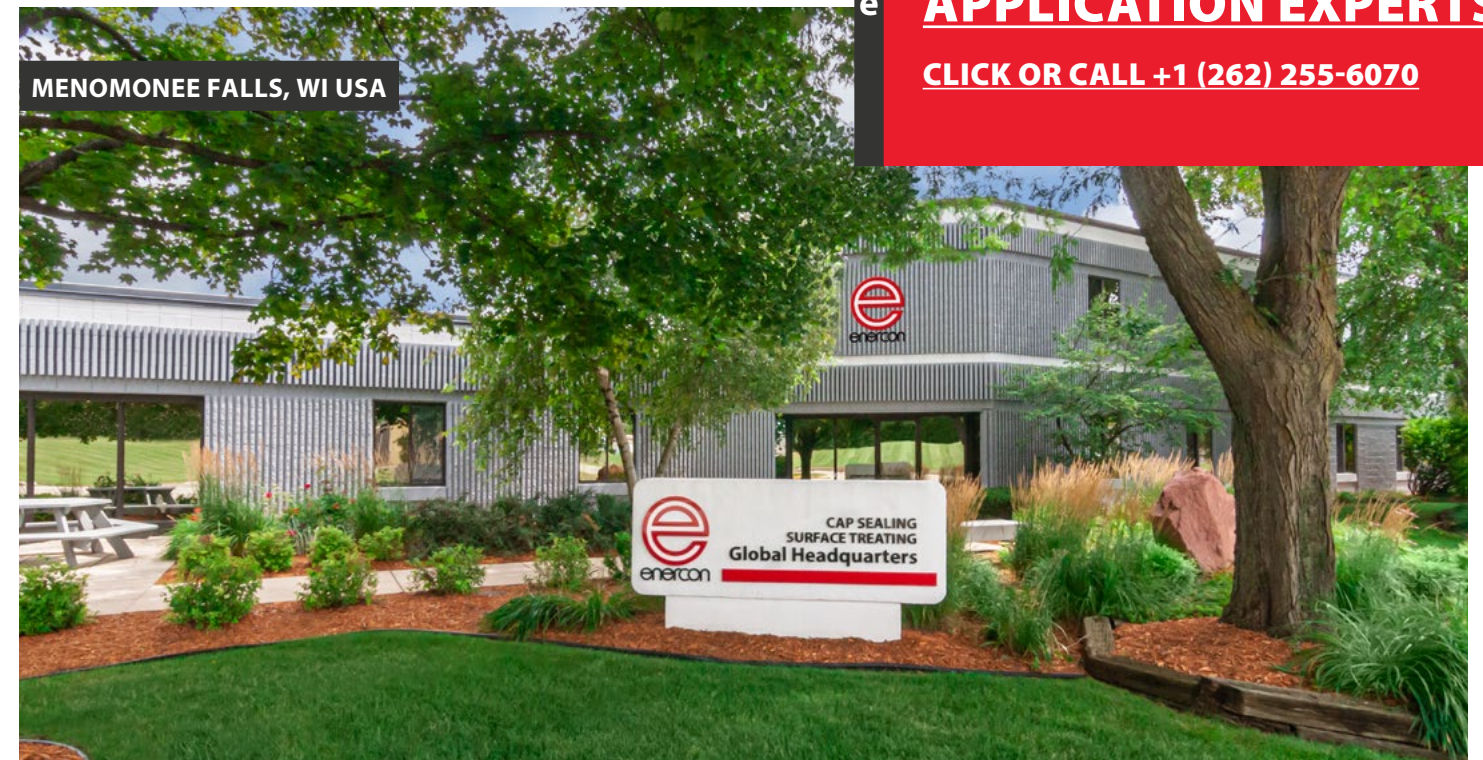



W140 N9572 Fountain Blvd.
Menomonee Falls, WI 53051 USA

+1 (262) 255-6070
www.enerconind.com/sealing